

Antenna STA3 Installation Instructions

Tools Required

10 mm x 2 or adjustable wrench





Mounting Pipe Diameter

20 – 48 mm

Preparation

Antenna STA3 is shipped from the factory with a fully assembled mounting kit (Figure 1). Unpack the antenna and check if all fixture parts (Table 1) are included.

Table 1: Mounting kit parts

Item	Qty.	Description	
1	4 pcs	M6 x 80 mm Hex Head Bolt	
2	8 pcs	M6 Hex Head Nut	
3	12 pcs	M6 Washer	
4	4 pcs	M6 Helical Lock Washer	
5	4 pcs	Bracket	

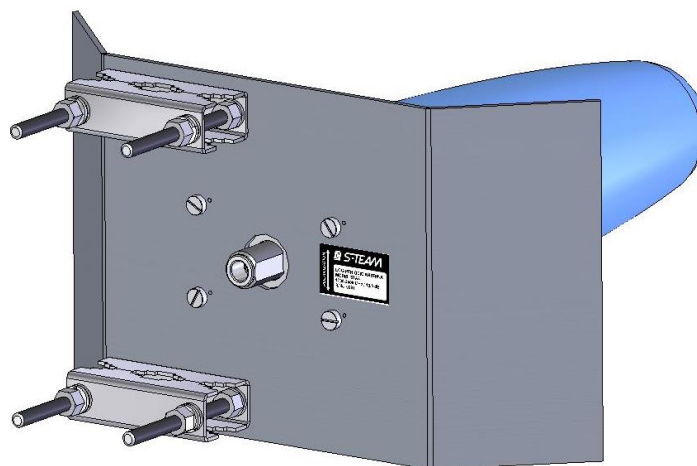

Figure 1

Installation

1. Unscrew the four M6 nuts and remove the helical lock washers, washers, and the two outer brackets (Figure 2).

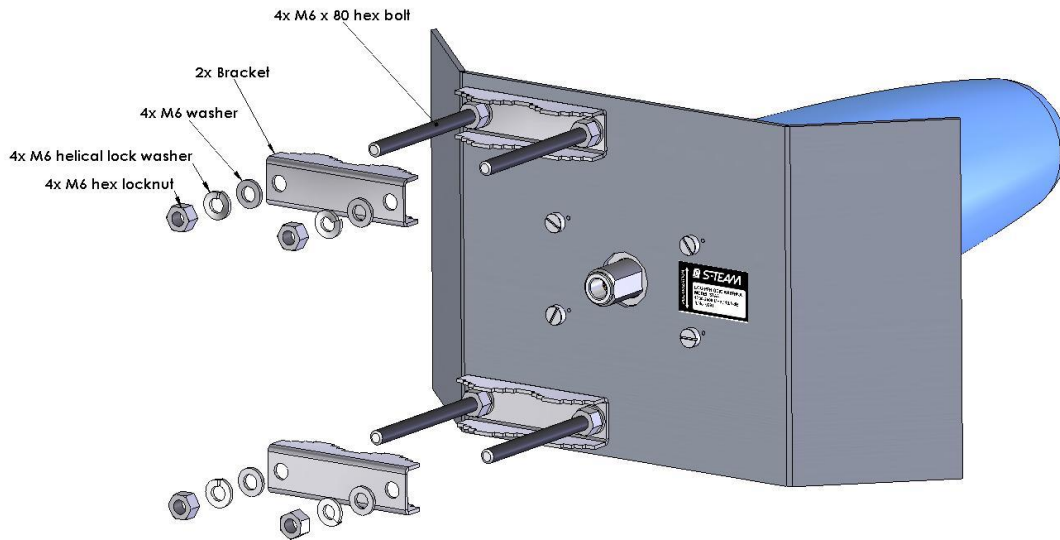

Figure 2

2. Properly orient the antenna and attach it to the mounting pipe (Figure 3). The antenna polarization is marked on the antenna label. For horizontal polarization, use a horizontally oriented mounting pipe.

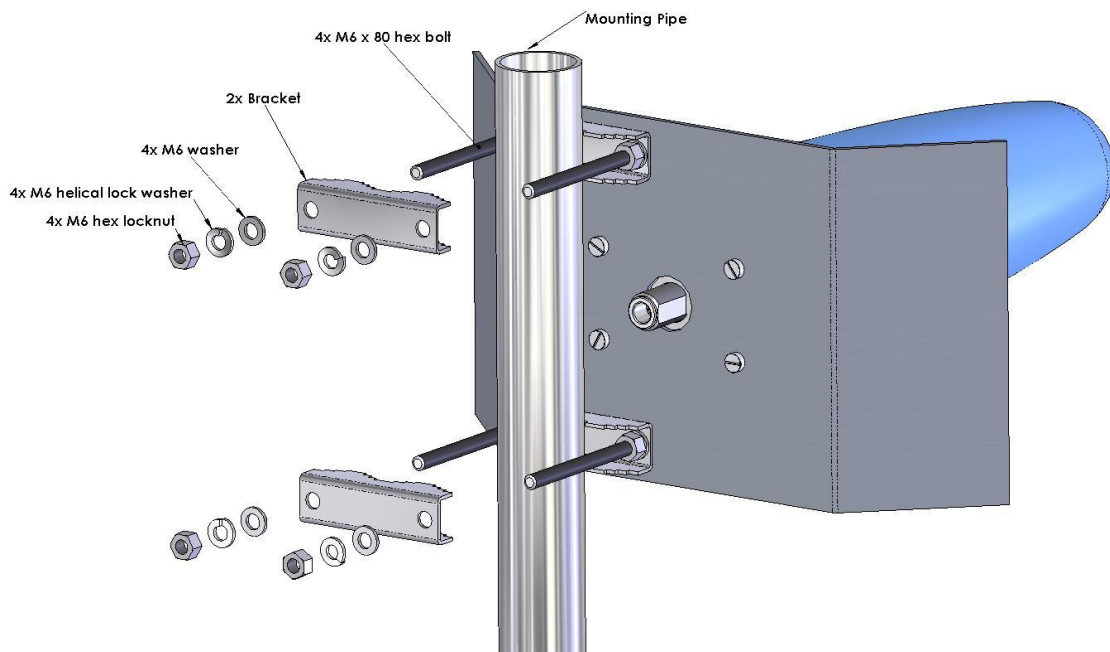

Figure 3

3. Insert the brackets, washers, helical lock washers, and M6 hex nuts (Figure 4). Tighten the nuts lightly by hand. Rotate the antenna to the desired direction. Tighten the nuts firmly with a wrench (torque 40 Nm).

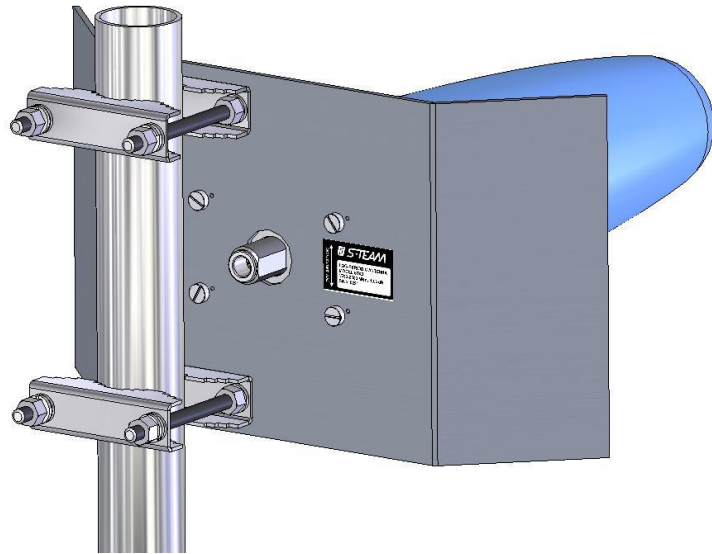

Figure 4

Notice

The installation, maintenance, or removal of an antenna requires qualified and experienced personnel.

- Do not install near power lines.
- Do not install on a wet or windy day or when lightning or thunder is in the area.
- Wear shoes with rubber soles and heels. Wear protective clothing including a long-sleeved shirt and rubber gloves.