

HOMER Autotuner ISM 5.8 GHz, R58 Waveguide

Contents

General Description	1
Principle of Operation	2
Modes of Sampling	2
<i>HomSoft</i> Windows Control, Visualization and Data Logging Software	3
Specifications	4
Configurations	5
Miscellaneous	6
Dimensional Drawing	7

General Description

The HOMER-Series STHT 5.8-GHz Autotuner (Fig. 1) integrates the HOMER Analyzer (automatic impedance and power measurement system) and HOMER Mototuner (a three-stub motorized tuner) in one compact unit. Based on the R58 (WR159) waveguide, the system works under the full-power operating conditions of magnetron-based microwave generators. The Analyzer part measures both the magnitude and phase of reflection coefficient as well as the incident, reflected and absorbed power, and frequency. The Mototuner consists of three stepping-motor-driven tuning stubs spaced in mutual distances of nominally one quarter of guide wavelength. The Tuner uses data measured by Analyzer for fast automatic impedance matching of time-varying loads in all industrial applications, including plasma. The system is designed for CW, high-ripple (Rectified) and Pulsed sampling modes. Also available is matching for non-zero reflection coefficient magnitude (defined mismatch tuning). The peak working power is set at the manufacture time as specified in the customer's order.

STHT can be:

- Used autonomously without an external controller.
- Controlled remotely from a personal computer or another controller via the following communication interfaces:
 - RS232 or RS422,
 - CAN (Controller Area Network),
 - Ethernet/IP.
- Integrated into a LabVIEW environment.

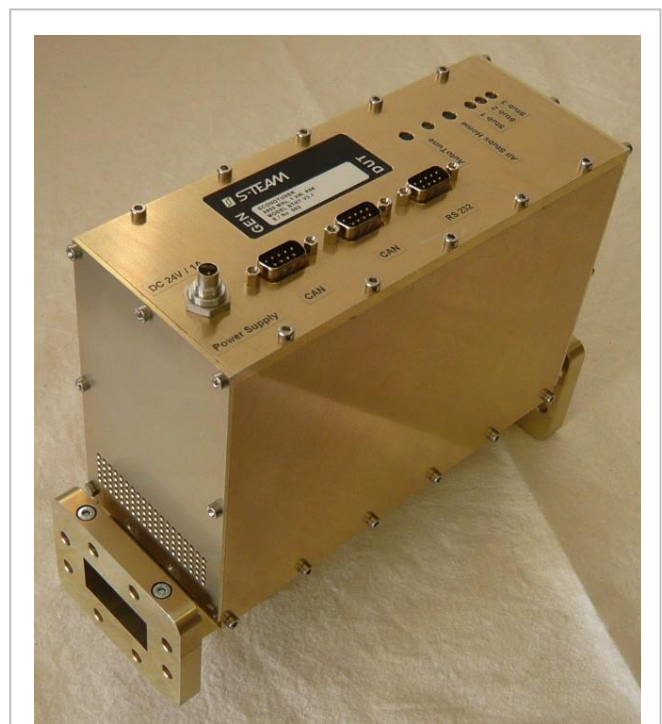

Fig. 1. HOMER Autotuner STHT 3.1.

Principle of Operation

The Analyzer part of STHT is based on the six-port reflectometer (SPR) principle. Reflectometers of this type are especially suitable for industrial applications where on-line monitoring and control under full working power is required. SPR is capable of measuring not only the complex reflection coefficient of the load but also the incident, reflected and absorbed powers. A frequency counter is also integrated with the system. The conceptual simplicity of SPR facilitates its stable and temperature-independent operation over long periods of time. The system parameters required for the computations are obtained in the process of factory-made calibration where a collection of impedance standards is connected in place of load. For best performance it is recommended that the recalibration be repeated each two years.

The Mototuner part of STHT uses an accurate measurement-based equivalent circuit for finding stub positions needed for matching loads, characterized by a complex reflection coefficient delivered from HOMER Analyzer part. Thanks to the predictive algorithm employed, time-consuming trial-and-error optimization schemes are avoided, enabling fast and accurate matching of even grossly mismatched loads.

Modes of Sampling

HOMER supports three modes of microwave power sampling, named *CW*, *Rectified*, and *Pulsed*.

- **CW mode** is applicable to unmodulated signals with power ripple not exceeding 15% of the peak value.
- **Rectified mode** is designed for slowly pulsing signals (up to several kHz repetition rate). Such signals are typical for magnetrons powered by economy power supplies which incorporate simple half-wave or full-wave rectifiers.
- **Pulsed mode** (optional) is intended primarily for sampling fast square pulse-modulated microwave signals with pulse widths down to 100 μs .

The *Rectified* and *Pulsed* modes provide both instantaneous and mean values of the reflection coefficient and the powers. Impedance matching is based on the mean value of the load reflection coefficient.

HomSoft Windows Control, Visualization and Data Logging Software

Although HOMER can operate as a stand-alone system, the *HomSoft* control, visualization and data logging software (Fig. 2) significantly expands its capabilities. The basic features include:

- Microsoft Windows® environment.
- Accurate measurement of complex reflection coefficient and its displaying in various formats, including
 - Magnitude
 - Phase
 - Return Loss
 - VSWR
 - Polar Display
 - Smith Charts (Z and Y)
 - Owen diagram (Rieke-type chart)
 - Frequency
- Measurement of incident, reflected, and absorbed powers and their displaying in various formats, including watts, decibels, percentage of incident power.
- Numerical readout of signal frequency, load reflection coefficient and power in various formats.
- Arbitrary shifting of the measurement plane.
- Saving measured data as tables (text files) or pictures (BMP, GIF, JPG).
- Periodic data logging of all measured quantities.
- Multiple windows enabling simultaneous observation of various quantities in different formats.
- Wide selection of appearances of displayed curves.
- Storing and retrieving of complete system settings tailored to particular tasks.
- Graphical interface for tuner control (manual stub movement, step-by-step/continuous autotuning)
- Prescribed scenario of tuning stub movements enables, among others, automated Rieke diagram measurement.
- DDE Server option enables other Windows applications to share measurement results.
- Extensive on-line help.

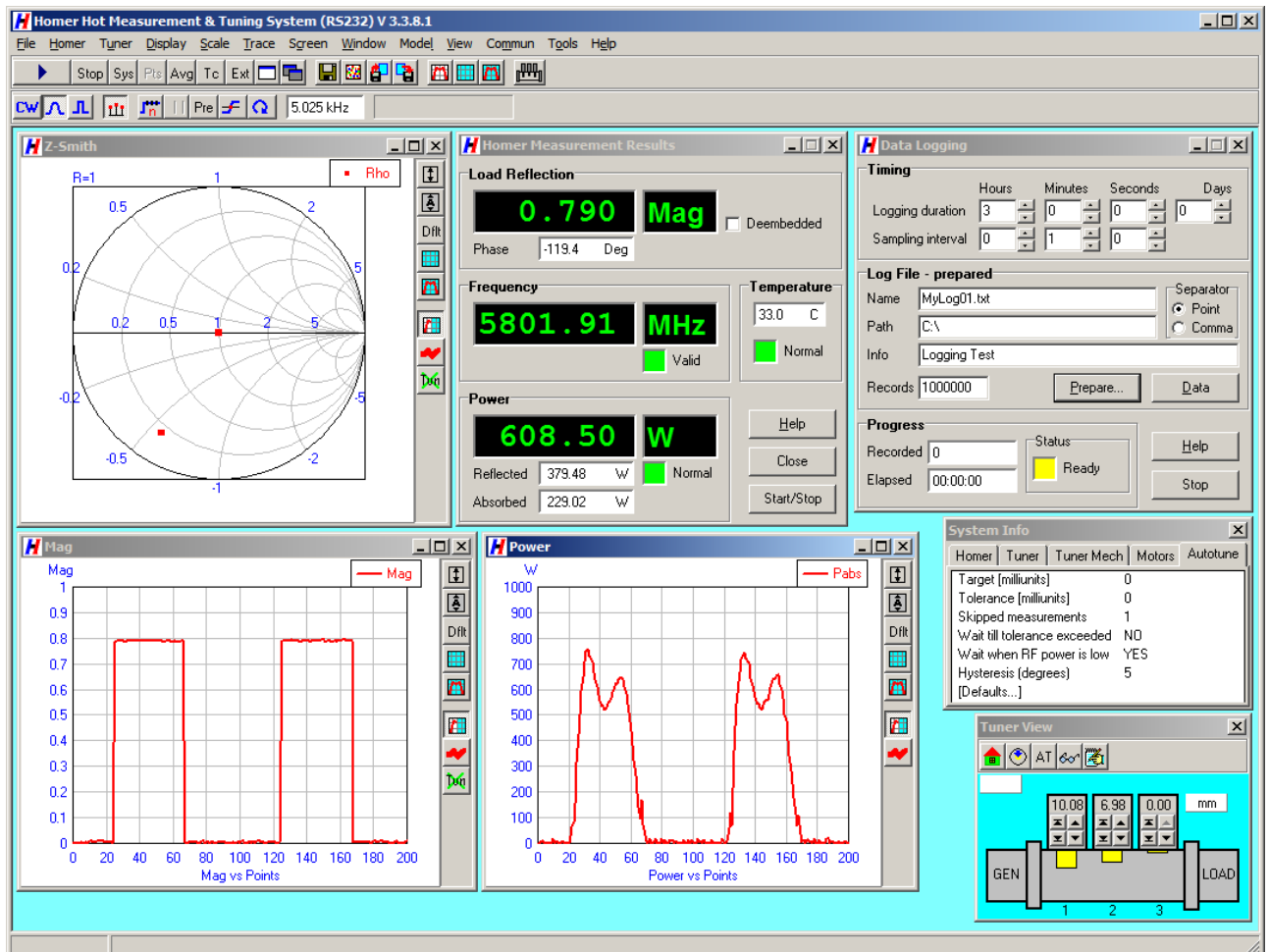

Fig. 2. Example of *HomSoft* graphical user interface.

Specifications

Electrical	
Waveguide type	R58 (WR159)
Flange type	IEC-UDR58
Frequency range	5725 – 5875 MHz
Available maximum working power ^{1 2 3}	20 W – 2 kW
Dynamic range of working power	20 dB
Reflection coefficient measurement error (uncertainty circle radius)	0.05
Incident power measurement error (matched load)	±5 %
Power supply voltage	24 V ±10% DC
Peak current consumption (all stubs moving)	1 A
Current consumption (stubs resting)	0.8 A
Interface	RS232, RS422, CAN, Ethernet/IP
Modes of signal sampling	CW, Rectified, Pulsed
Max acceptable ripple in CW mode	15 % of peak value
Max repetition rate of signal envelope in Rectified mode ⁴	10 kHz
Min pulse width in Pulsed mode	100 µs
Tuner	
Max tuning stub travel	11 mm
Tuning range	VSWR < 10:1
Tuning accuracy (reflected-to-incident power ratio)	1 %
Full stub insertion travel time	0.7 s
Time to achieve match	Depends on load mismatch, initial stub positions and signal quality ⁵
Mechanical	
Mass	3 kg
Length	237.4 mm (9.34 in)
Width	80.8 mm (3.18 in)
Height	192.3 mm (7.57 in)
Surface finish	E-CLPS 4600

Notes:

¹ Actual maximum working power is hardware-fixed according to customer's demand (must be within the Specifications limits). Posterior changing of the peak working power requires hardware modification and partial unit recalibration, and therefore must be done at the factory.

Minimum working power is 20 dB (= dynamic range) below the actual maximum working power.

² The maximum working power is specified for **matched load** conditions. For loads with high reflection coefficient magnitude (> 0.9), the applied power must be lowered to avoid arcing for deeply inserted tuning stubs. Please contact the manufacturer for details.

³ In Rectified and Pulsed modes, maximum power means **peak** power (not its mean value).

⁴ Signal envelope repetition rate (ripple frequency) f_e is determined by power line frequency f_p and rectification method. Examples: One-phase half-wave rectification $f_e=f_p$; one-phase full-wave rectification $f_e=2f_p$; three-phase half-wave rectification $f_e=3f_p$; three-phase full-wave rectification $f_e=6f_p$; three-phase Y+Δ half-wave rectification $f_e=6f_p$; three-phase Y+Δ full-wave rectification $f_e=12f_p$.

⁵ For tuning speed details, see S-TEAM Application Note AN-0901.

Configurations

Basic Configuration

- STHT Basic Unit
- Internal firmware (Server)
- Calibration in 5725 – 5875 MHz band
- RS232 or RS422 serial interface
- CW and Rectified modes of sampling
- Operating handbook (pdf)
- Communication protocol manual (pdf)
- Set of standard cables⁶

Options

1. *HomSoft* Windows visualization and control software
2. Pulsed mode of sampling
3. Defined mismatch tuning
4. CAN Bus communication interface (includes CAN Bus cable)
5. CAN-USB Adapter (to connect a PC to CAN Bus network)
6. LabVIEW HOMER Virtual Instruments Library
7. Dynamic Data Exchange (DDE) server in *HomSoft* Windows SW⁷
8. Technical support in hours
9. n/a
10. Digital input for selected HOMER commands
11. Ethernet/IP communication interface

Optional Power Supplies

- Traco Power TBL 150-124, 24V/6.25A, DIN rail mountable
- Electro-Automatik EA-PS-524-11T, 24V/10.5A, input 90-264 V, benchtop

Notes:

⁶ Set of standard cables includes DC power supply cable, RS232/RS422 cable, and (in case of CAN Bus) CAN Bus cable.

⁷ *HomSoft* Windows visualization and control SW option required.

Miscellaneous

Defined Mismatch Tuning. Some installations (notably some plasma applicators) may work better when the result of autotuning is not a zero reflection coefficient but a slight mismatch. Defined Mismatch Tuning option enables such tuning method, resulting in a reflection coefficient that has a user-specified, nonzero magnitude. The phase is uncontrolled.

CAN-USB Adapter. To connect your PC with a CAN Bus network (or with the STHT alone), the *Sontheim CAN USB Light Dongle* adapter is needed. You can order it as an option. Another possibility is to buy the dongle yourself from the manufacturer (visit <http://www.s-i-e.de>).

LabVIEW HOMER Virtual Instruments Library enables HOMER monitoring and control from within the National Instruments' LabVIEW environment. The library consists of a collection of virtual instruments (see an example in Fig. 3) and includes several useful examples. The library enables users to integrate HOMER into their own applications with much less effort than trying to start from scratch by studying HOMER communication protocol and programming the complete communication.

DDE Server. DDE Server is a functionality within the *HomSoft* Windows visualization and control SW, and hence it needs the *HomSoft* option, too. The DDE Server enables another (customer's) Windows program, e.g., Microsoft Excel, to extract measurement results from running *HomSoft*.

Technical support. It often happens that new users, especially in the initial phase, need counsel about issues that are not directly a matter of HOMER itself but of their particular application, or about topics that are in fact described in the accompanying documentation. Four hours of such support are provided free of charge; additional support should be ordered.

Digital input for selected HOMER commands. This option enables selected HOMER commands to be remotely triggered by an external 24-V pulse. Currently, the commands include *Autotune ON/OFF*, *Single Autotuning Step*, and *All Motors Home* procedure.

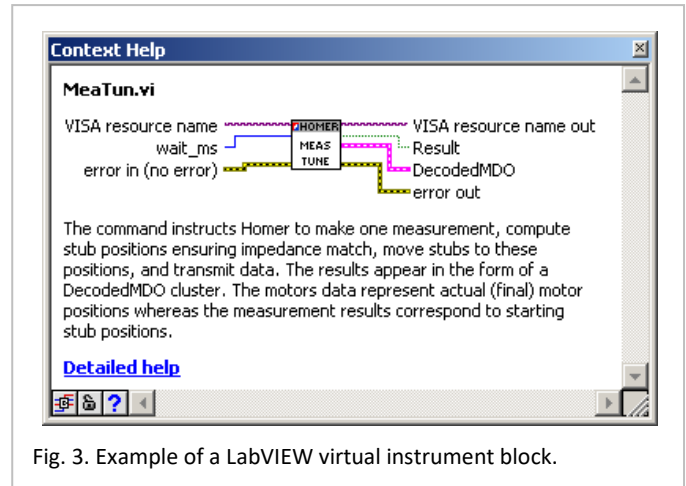

Fig. 3. Example of a LabVIEW virtual instrument block.

Dimensional Drawing

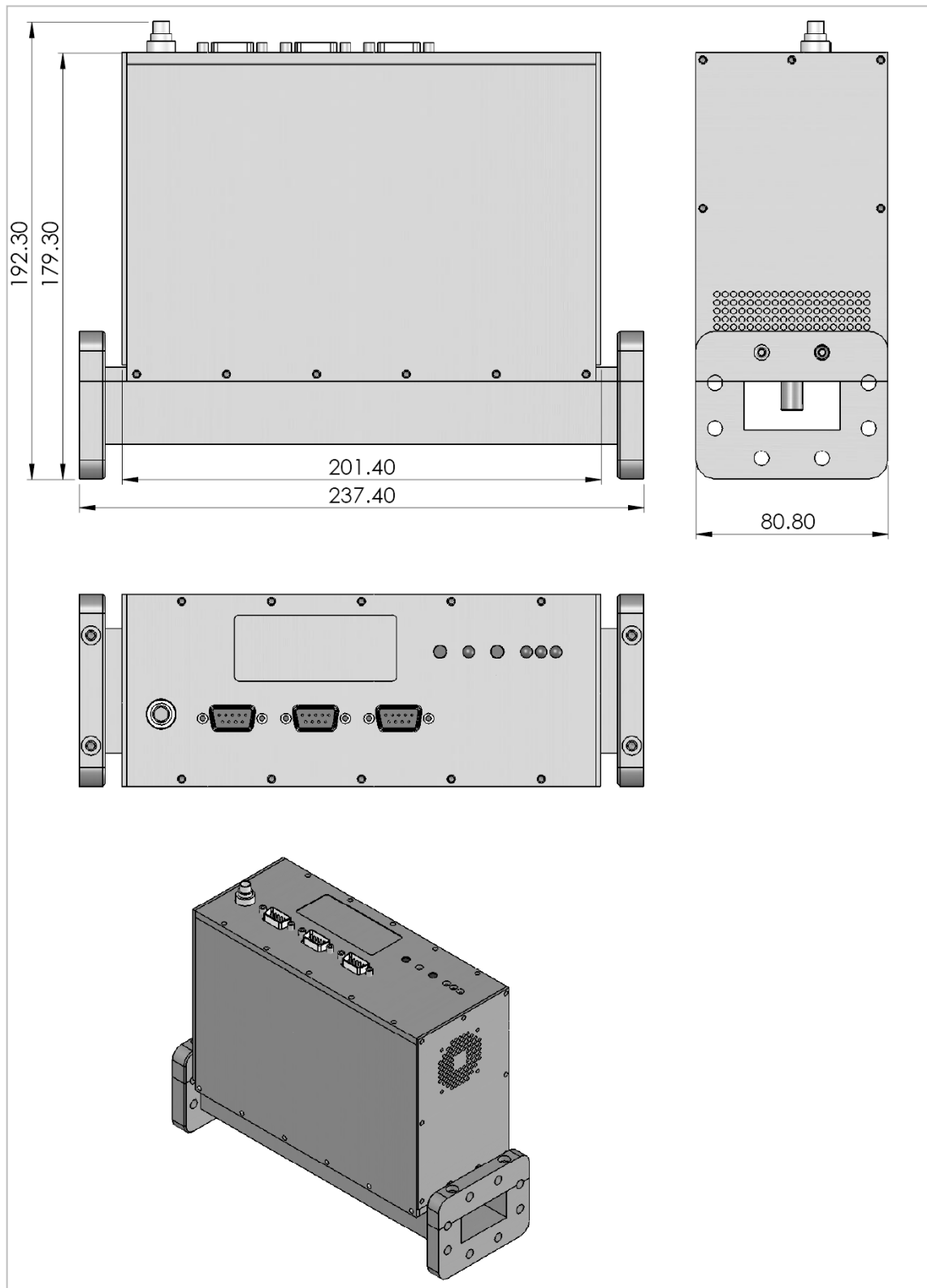

Fig. 4. Basic dimensions of STHT 3.1. All dimensions are in millimeters.