

BC211: Bidirectional Coupler for WR-975 Waveguide

General Description

BC211 (Fig. 1) is a dual directional (bidirectional) coupler intended for simultaneous sampling of the powers of the incident and reflected waves in high-power 900 MHz industrial applications using WR-975 (R-9) rectangular waveguide.

The coupling mechanism involves two probes (antennas) inserted into the waveguide, outputs of which are appropriately combined and distributed to the two output connectors.

The coupler integrates two attenuators to isolate the internal coupling structure from the coupled port loads, and to improve the coupled port match.

Two coupling factor options are available: -60 dB for maximal waveguide working power 10 kW, and -70 dB for maximal working power 100 kW.

The BC211 coupler module is fastened to a parent waveguide by means of six M3 or similar-diameter screws after machining of appropriate holes in the waveguide wall (see the waveguide machining template shown in Fig. 5).

As an option, a calibrated assembly consisting of a BC211 fixed to a precisely machined parent waveguide with the standard length 300 mm can be provided (Fig. 2).



Fig. 1. Bidirectional coupler BC211.



Fig. 2. BC211 installed on the standard-length waveguide.

Specifications

Waveguide of destination	R9 (WR975)
Waveguide wall thickness	4 mm, optionally 0.125 inch
Waveguide surface flatness required at BC interface	0.04 mm
Frequency range	895 – 925 MHz
Coupling factor/Max working power	-60 dB / 10 kW -70 dB / 100 kW
Coupling factor uncertainty limits (3- σ deviation)	± 1 dB
Directivity	25 dB min
Coupled ports impedance	50 Ω
Coupled ports connectors	SMA female
Dimensions (L x W x H)	143.5 x 59.2 x 23 mm
Mass	215 g
Surface finish	E-CLPS 4600
Operating temperature range	-10 °C to +65 °C
Storage temperature range	-20 °C to +80 °C

Typical Directivity

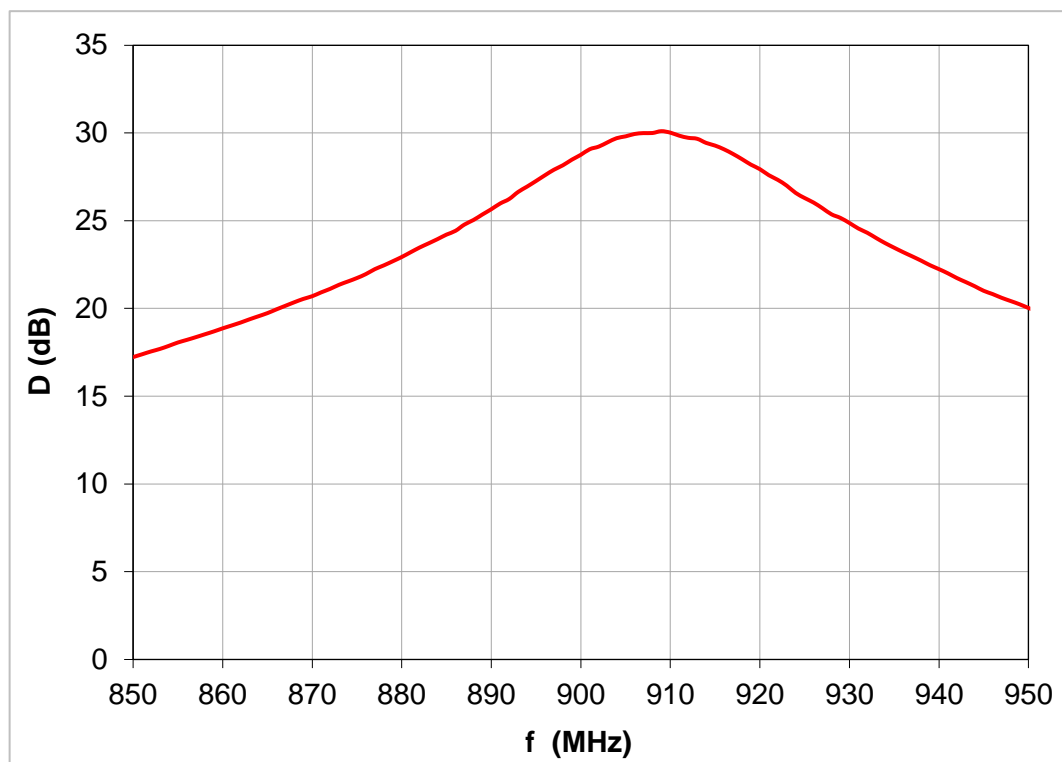

Fig. 3. Typical BC211 directivity (both directions).

Dimensional Drawing

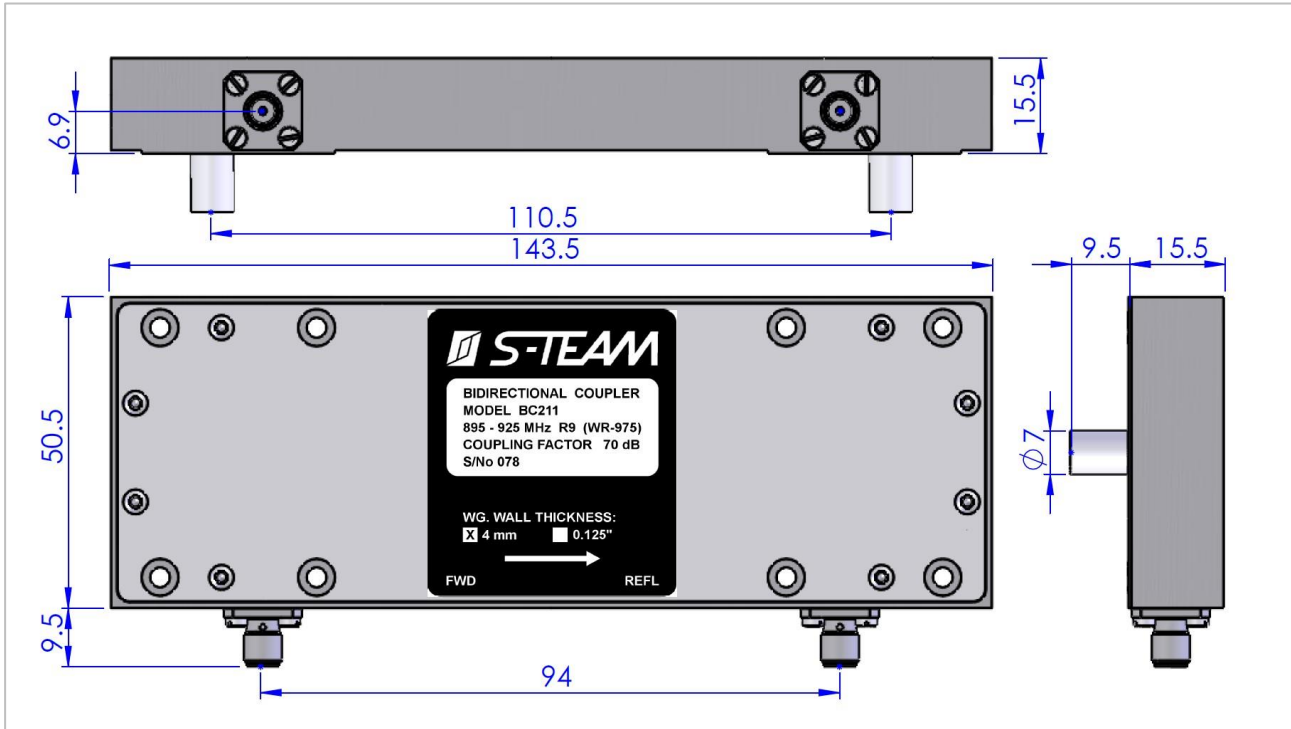

Fig. 4. Basic BC211 dimensions. All dimensions are in millimeters.

Waveguide Machining Template

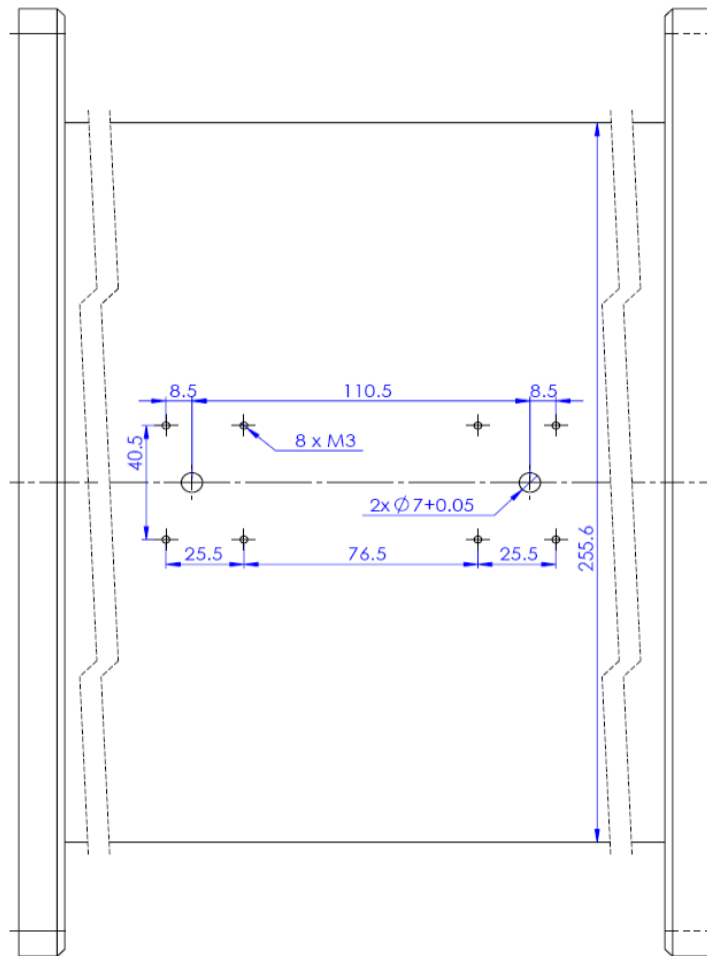

Fig. 5. Waveguide machining template. All dimensions are in millimeters. The pattern is centered about the waveguide axis. Unless the option 0.125" is requested, the waveguide wall thickness must be 4 mm. Suggested screws: M3 x 13 or M3 x 12 (stainless or galvanized steel).

Important Note

Complying with the specified waveguide wall thickness and flatness of its surface interfacing with the BC211 is essential for the specified coupling factor. The slope of the coupling factor as a function of the wall thickness is about -6 dB/mm (increasing the wall thickness decreases the coupled power).

If the wall thickness differs from the specified figure but is known, a user-defined correction based on the above slope can be applied. Nevertheless, the wall thickness should not deviate from the specification by more than ± 0.3 mm, otherwise the BC211 directivity will deteriorate.

To avoid problems with manufacturing precision waveguide components, a calibrated assembly consisting of a BC211 module fixed to a parent waveguide can be ordered. The standard waveguide length is 300 mm.