

DM212: Fast Temperature-Stable Microwave Detector

Description

DM212 (Fig. 1) is a tunnel diode coaxial microwave detector covering the frequency range 100 MHz – 4 GHz but intended primarily for 915 MHz and 2450 MHz industrial applications.

The detector delivers well-scaled DC voltage approximately proportional to the input power. The tunnel diode ensures high temperature stability of the output voltage and low video resistance for fast pulse rise/fall times.

Standard output voltage polarity is negative; optionally, it can be positive (DM212P).



Fig. 1. Detector DM212.

Specifications

Frequency range	880 – 930 MHz	2350 – 2550 MHz
Frequency response variation (max)	±0.25 dB	±0.5 dB
Typical output voltage for $P = 1 \text{ mW}$, $R_{\text{LOAD}} = 33 \text{ k}\Omega$	220 mV	230 mV
VSWR max	2	
VSWR typ	1.3	
Statistical spread of output voltage	±1 dB (3- σ deviation)	
Output voltage polarity	Negative (optionally positive)	
Output voltage temperature variation (5 to 65 °C)	< 0.5 dB	
Video resistance (typ)	250 Ω	
Max input working power	1 mW	
Max input power (destruction limit)	20 mW	
Input RF connector	N-male	
Output DC connector	BNC-female	
Dimensions (L × W × H)	58 × 26 × 26 mm	
Mass	90 g	
Operating temperature range	-10 °C to +65 °C	
Storage temperature range	-20 °C to +80 °C	

Typical Transfer Characteristics

Typical detector transfer characteristics for an ambient temperature of $T_a = 25\text{ }^\circ\text{C}$ and load resistance $R_L = 33\text{ k}\Omega$ are shown in Fig. 2, where P is the input microwave power in dBm and V is the (negative) output DC voltage in mV. Note that $P_{\text{dBm}} = 10 \cdot \log(P_{\text{mW}})$.

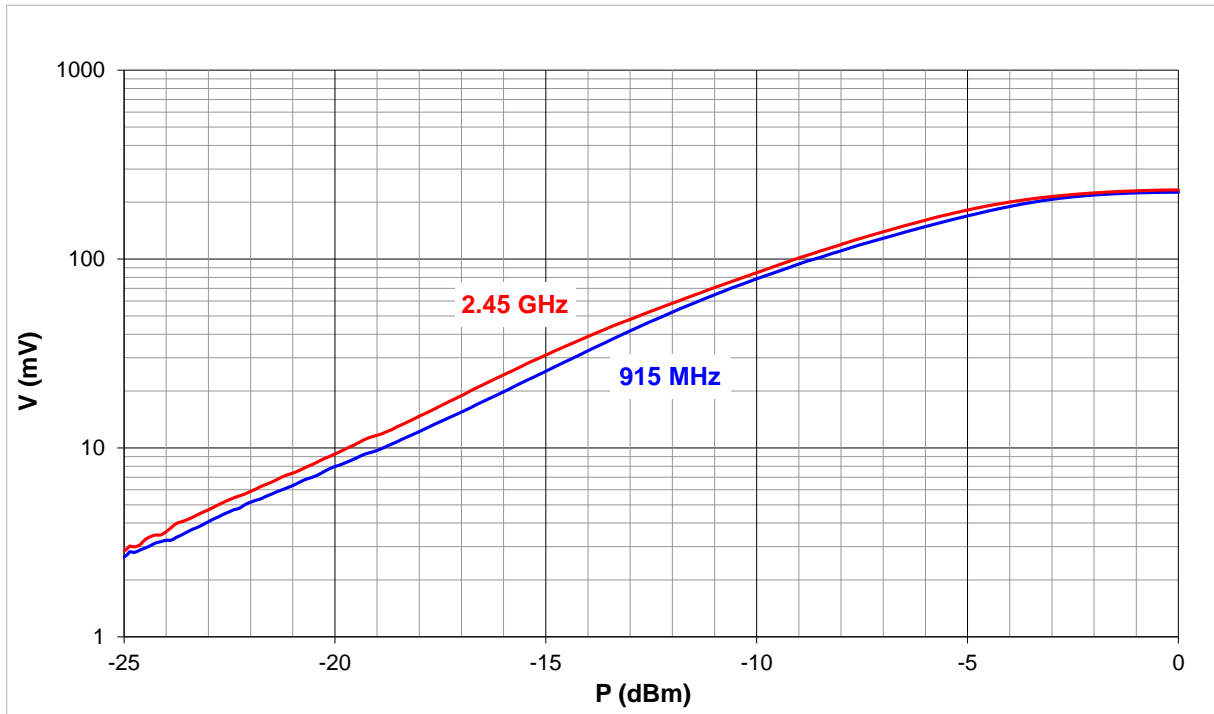

Fig. 2. Typical DM212 transfer characteristics.

Detector Correction Curves

A detector correction curve is the inverse of the transfer curve. It can serve, in particular in its mathematical form, for determining the input power from the output voltage. Fig. 3 shows a typical DM212 correction curves in lin-lin format.

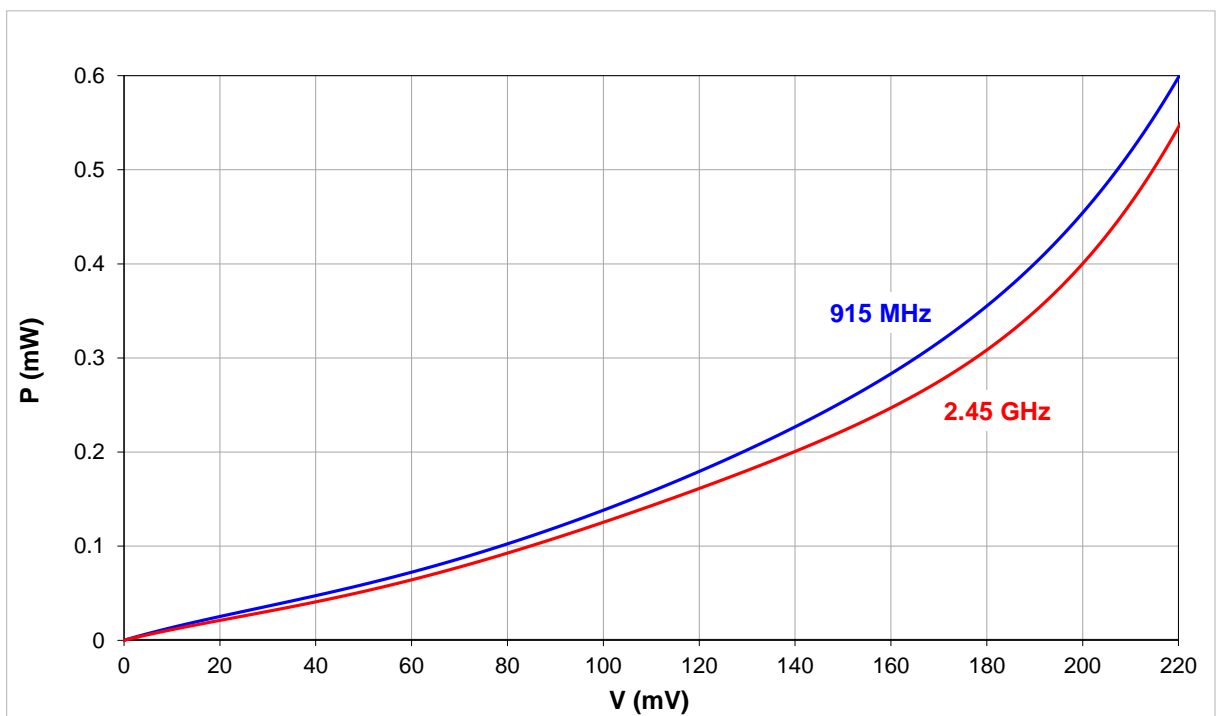

Fig. 3. Typical DM212 correction curves.

The curves can be approximated by the polynomial

$$P = d_1 V + d_2 V^2 + d_3 V^3 + d_4 V^4 + d_5 V^5$$

where P is the input microwave power in milliwatts, V is the output voltage in millivolts, and d_i are the coefficients listed in Tab. 1. The curves in Fig. 3 and the coefficients in Tab. 1 are valid for $T_a = 25\text{ }^\circ\text{C}$, $R_L = 33\text{ k}\Omega$ and for the output voltages not exceeding 210 mV (to avoid using the detector in the saturation region).

Tab. 1. Polynomial coefficients for the DM212 detector correction curves.

Frequency:	915 MHz	2.45 GHz
d_1	1.4903894E-03	1.2430940E-03
d_2	-1.6404612E-05	-1.4451703E-05
d_3	2.7777734E-07	2.9077875E-07
d_4	-1.6104676E-09	-1.9062158E-09
d_5	3.6466985E-12	4.5418784E-12

Note

Please be aware that these functions are a statistical average based on evaluation of a number of detectors. The behavior of individual detectors may vary.

Dimensional Drawing

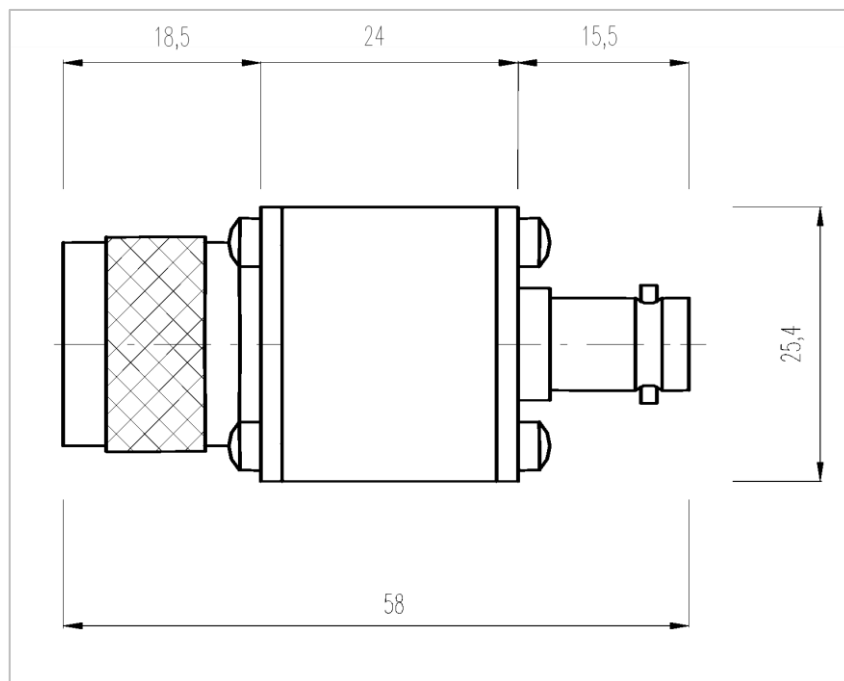

Fig. 4. Basic DM212 dimensions (millimeters).