

## DD111: Directional Detector for R26 Waveguide

### General Description

DD111 (Fig. 1) is a small-housing directional detector that is intended for sampling incident or reflected waves in high-power 2450 MHz industrial applications using an R26 (WR340) rectangular waveguide. This detector combines the following components:

- Directional coupler
- Attenuator
- Tunnel diode detector

The detector delivers well-scaled DC voltage approximately proportional to the power of a wave propagating in one direction in the parent waveguide. The use of the tunnel diode provides an improved temperature stability of the output voltage and a low video resistance for fast pulse rise/fall times.

The detector transfer curve is generally nonlinear and varies with temperature. A transfer curve of an “average detector” is presented in this datasheet.

The detector module is fastened to a parent waveguide by means of six M3 or similar-diameter screws after machining of appropriate holes in the waveguide wall. Simply reversing the module causes it to sample the wave propagating in the opposite direction.

As an option, an assembly consisting of one module or two reverse-oriented modules affixed to a precisely machined parent waveguide with the standard length 174 mm can be provided.



Fig. 1. Directional detector DD111.

### Specifications

Waveguide of destination	R26 (WR340)
Waveguide wall thickness	2 mm
Waveguide surface flatness required at DD interface	0.04 mm
Frequency range	2425 – 2475 MHz
Maximum working power	16 kW
Directivity	25 dB min
Output voltage polarity	Negative
Video resistance (typical)	250 $\Omega$
Internal output capacitance	1500 pF
Statistical spread of output voltage	$\pm 1$ dB (3- $\sigma$ deviation)
Output voltage temperature variation (+5 °C to +65 °C)	< 0.5 dB
Dimensions	46 mm $\times$ 49.5 mm $\times$ 22 mm
Mass	70 g
Operating temperature range	-10 °C to +65 °C
Storage temperature range	-20 °C to +80 °C
Output connector	SMA female (SMAf)

## Detector Correction Curve

A detector correction curve is the inverse of the transfer curve  $V = f(P)$  where  $P$  is the power of a wave propagating in the waveguide in a given direction and  $V$  is the output voltage. The correction curve can serve, in particular in its mathematical form, for determining the input power from the output voltage. Fig. 2 shows a typical correction curve for an ambient temperature of  $T_a = 25\text{ }^\circ\text{C}$ , frequency 2450 MHz, and load resistance  $R_L = 33\text{ k}\Omega$ .

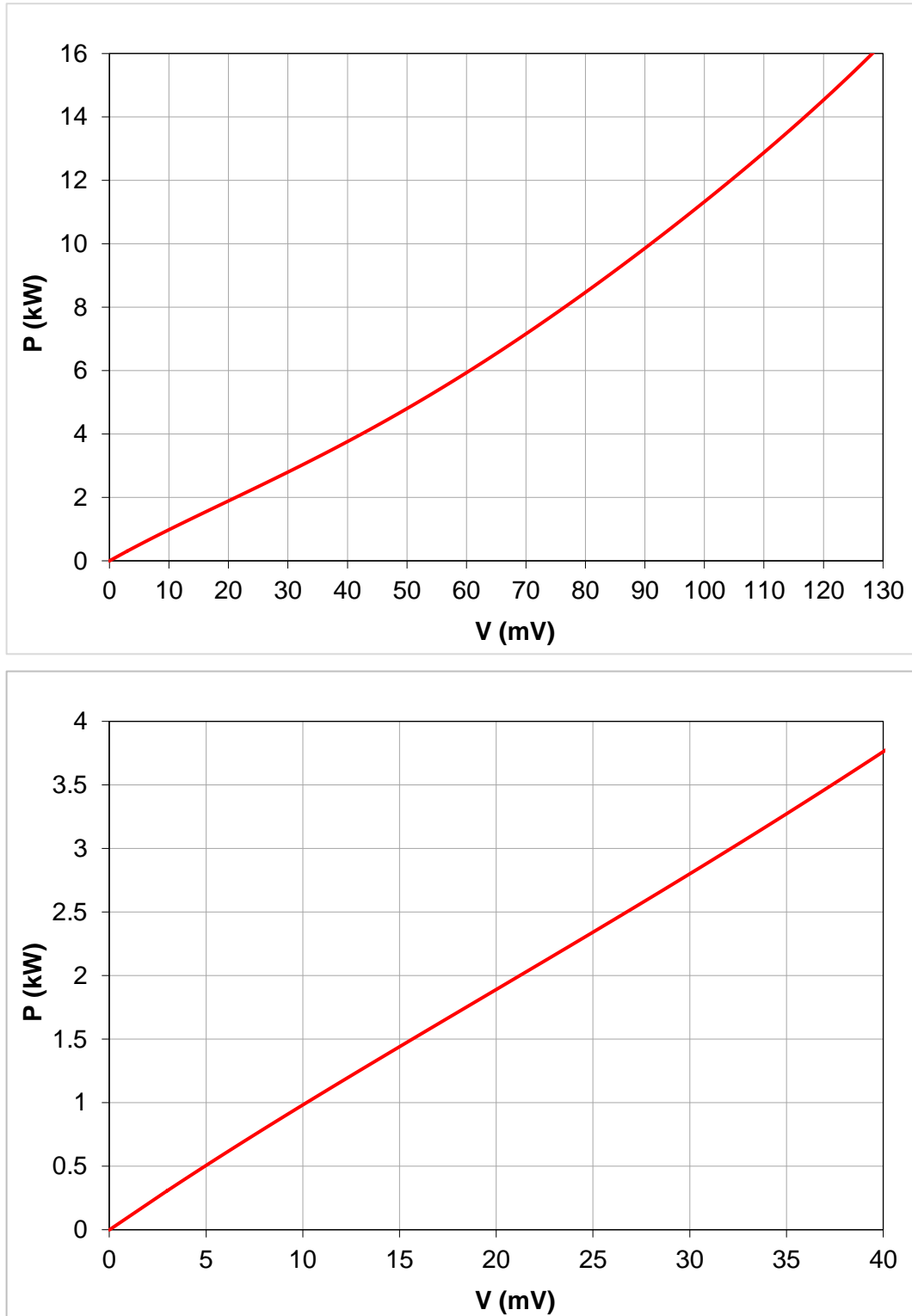

Fig. 2. Typical DD111 correction curve.

The curve can be approximated by the polynomial

$$P = d_1 V + d_2 V^2 + d_3 V^3 + d_4 V^4 + d_5 V^5$$

where  $P$  is the input microwave power,  $V$  is the output voltage in millivolts, and  $d_i$  are the coefficients listed in Tab. 1.

Tab. 1. Polynomial coefficients for DD111 correction curves.

Coefficient	Value
$d_1$	1.0537451E-01
$d_2$	-8.9899544E-04
$d_3$	2.0879498E-05
$d_4$	-1.5362224E-07
$d_5$	4.2649132E-10

Please be aware that this function is a statistical average based on evaluation of a number of detectors. The behavior of individual detectors may vary.

## Dimensional Drawing

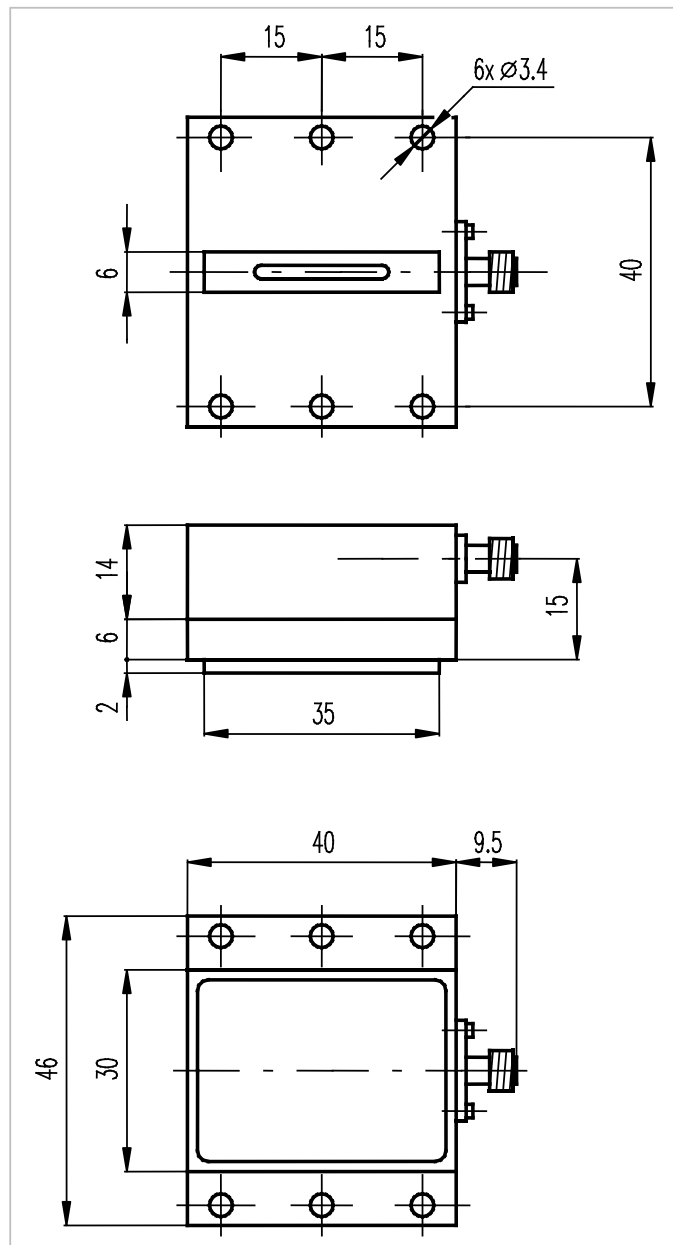

Fig. 3. Basic DD111 dimensions. All dimensions are in millimeters.

## Waveguide Machining Template

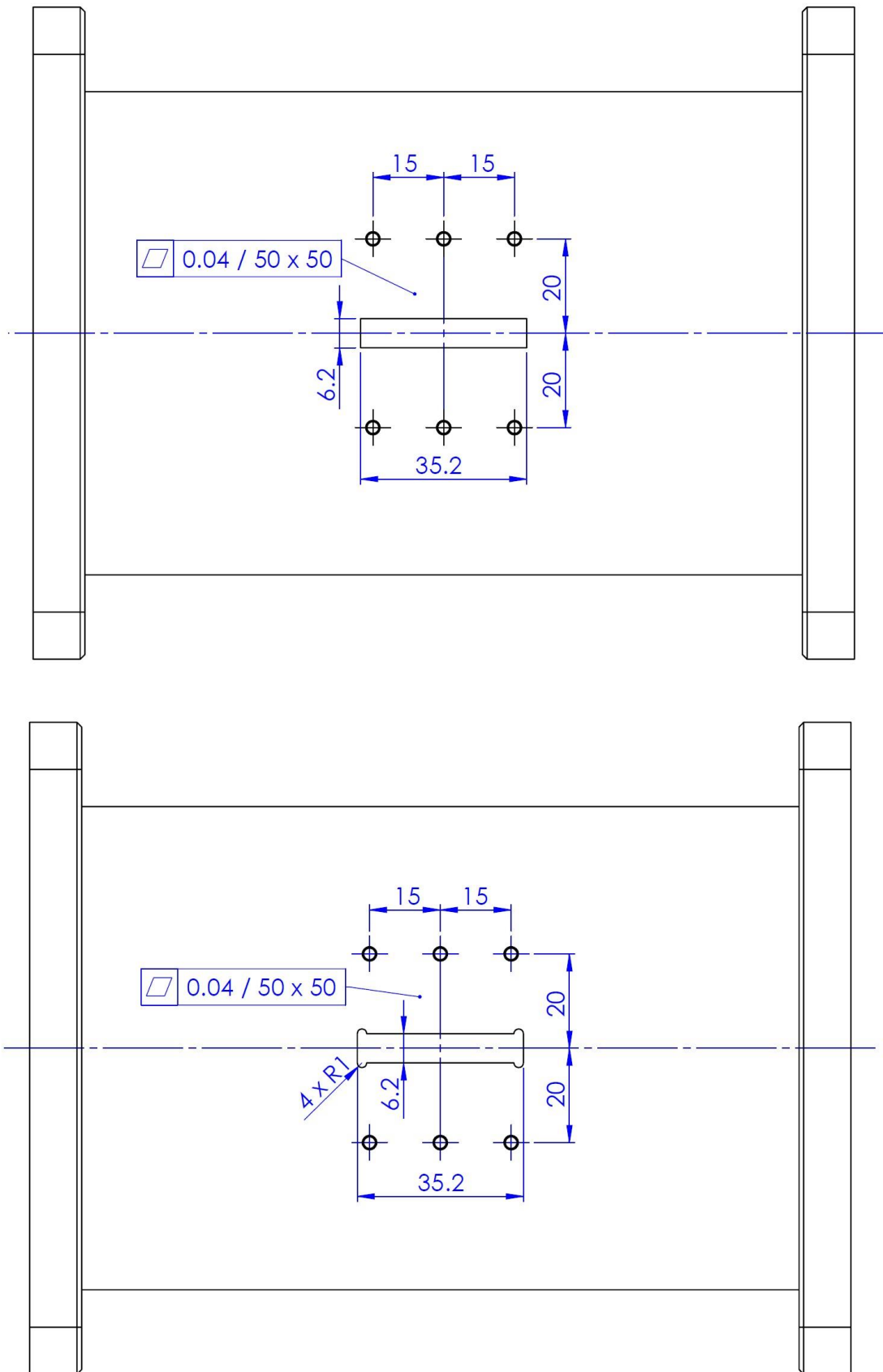

Fig. 4. Waveguide machining template. All dimensions are in millimeters. The bottom alternative is for a better manufacturability. The waveguide wall thickness **must be 2 mm**. Suggested are M3 x 8 screws (stainless or galvanized steel).

**Important Note**

Complying with the specified waveguide wall thickness and flatness of its surface interfacing with the detector is essential in order to achieve the specified measurement accuracy. The wall thickness should not deviate from the specification by more than  $\pm 0.3$  mm, otherwise the DD directivity will deteriorate.

To avoid problems with manufacturing precision waveguide components, a calibrated assembly consisting of one or two DD modules fixed to a parent waveguide can be ordered. The standard waveguide length is 174 mm.